

DIMENSIONES GENERALES

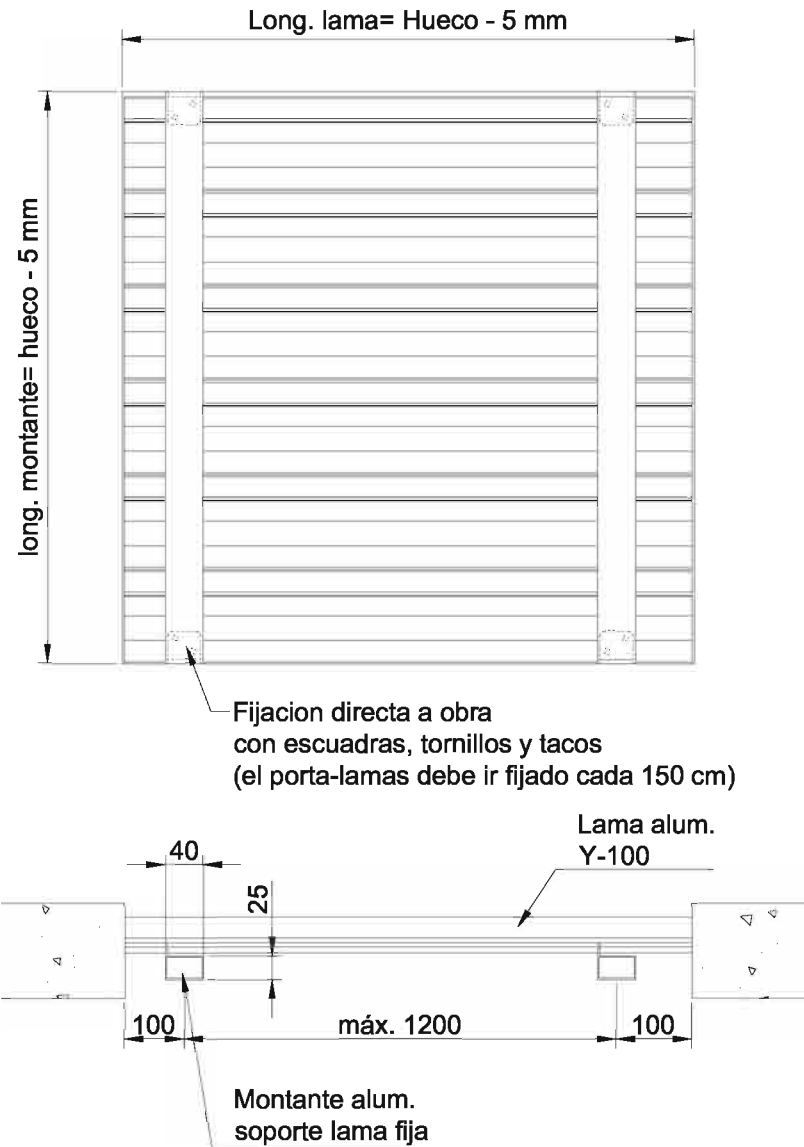

Solución entre muros

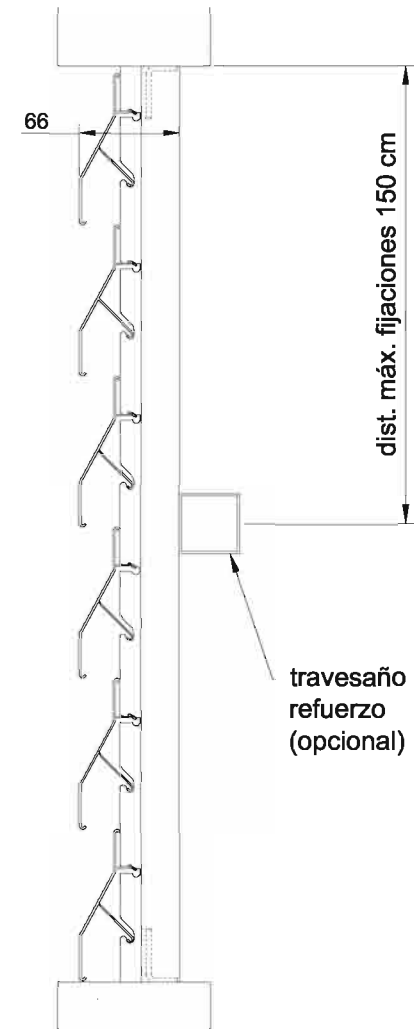

SEPARACIÓN ENTRE LAMAS

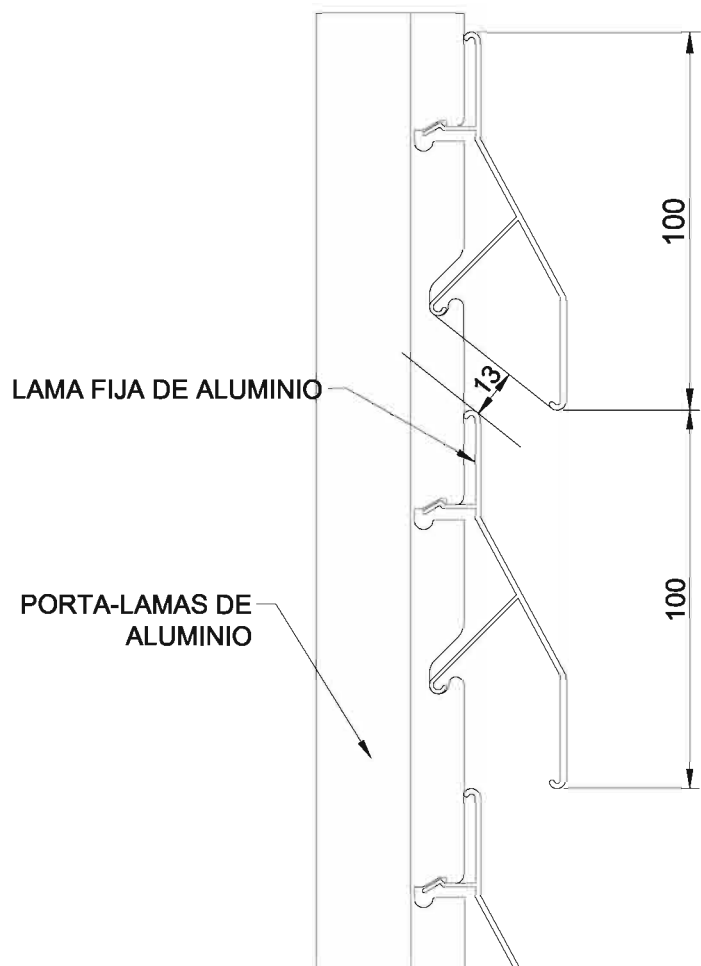

PASO 100
Ventilación= $13/100 \times 100 = 13\%$

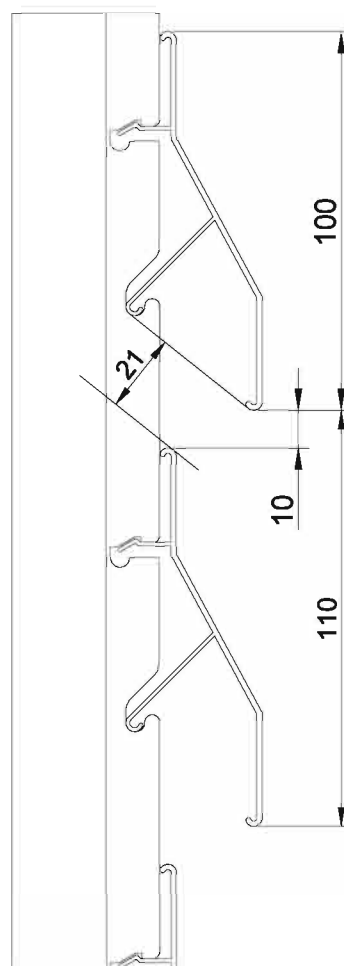

PASO 110
Ventilación= $21/110 \times 100 = 19\%$

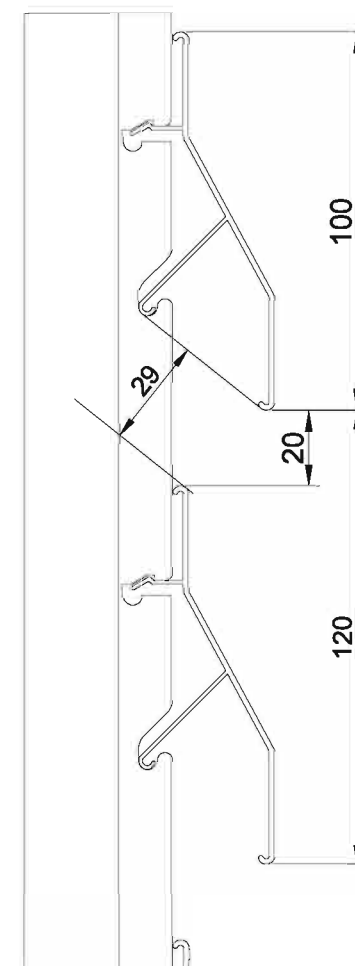

PASO 120
Ventilación= $29/120 \times 100 = 24\%$



Industrias Durmi S.A.

Pol. Ind. "La Vilanoveta" C/ Dos, S/N, Sant Pere de Ribes, Barcelona. Tel: (0034) 938 932 754 Fax: (0034) 938 933 560 www.durmi.com durmi@durmi.com Debido a la constante evolución de los productos, todas las especificaciones están sujetas a cambios sin previo aviso.



